

LEGEND 3 AXIS CNC

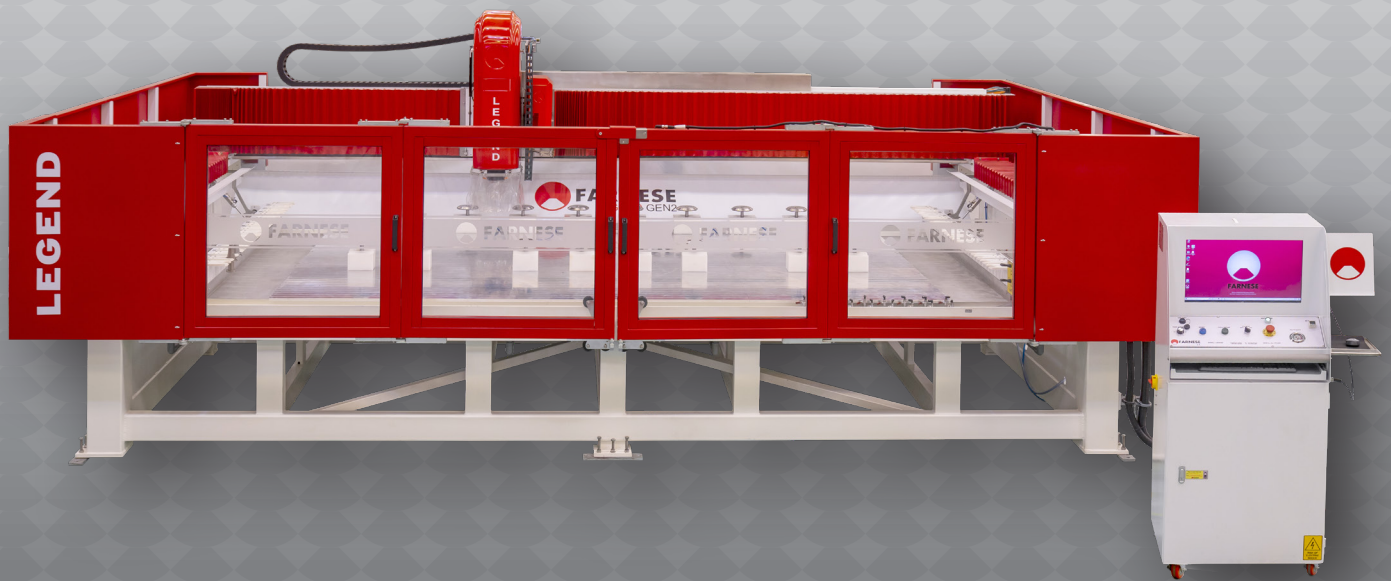

DESIGN FEATURES

A FULL SIZE 3 AXIS CNC

INCLUDES TAGLIO CAD/CAM SOFTWARE

TOUCH SCREEN CONTROL

EASY SINK CUT OUTS AND TAP HOLES

INTERNAL / EXTERNAL EDGE PROFILING AND POLISHING

AUTOMATIC LUBRICATION SYSTEM

AUTOMATIC TOOL CHANGE WITH 32 POSITIONS

RECESSED DRAINBOARDS AND INCLINED GROOVES

Farnese Australia was founded in 2000 by the Farnese family, whose members have decades of combined professional experience and expertise in both the global stone industry and the local stone machinery manufacturing industry. We are the only designer and manufacturer of stone fabrication machinery in Australia and our machines have found homes throughout Australia, New Zealand, the United States, the United Kingdom, and Vietnam.

With over 20 years of experience in the stone industry, the team at Farnese have the experience it takes to design, install and maintain the equipment needed in your industry.

The LEGEND is a cost efficient, large table, 3 Axis CNC work centre capable of all functions relevant to today's benchtop manufacturing.

The LEGEND has been designed to accommodate any size work piece, be it large or small. Due to its size, the true benefit can be seen in its ability to handle extremely large work pieces, or alternatively, multiple smaller pieces.

Being a monoblock design, installation is a relatively simple process. The machine is easy to lift into place and commission, allowing our technicians to begin the training process sooner.

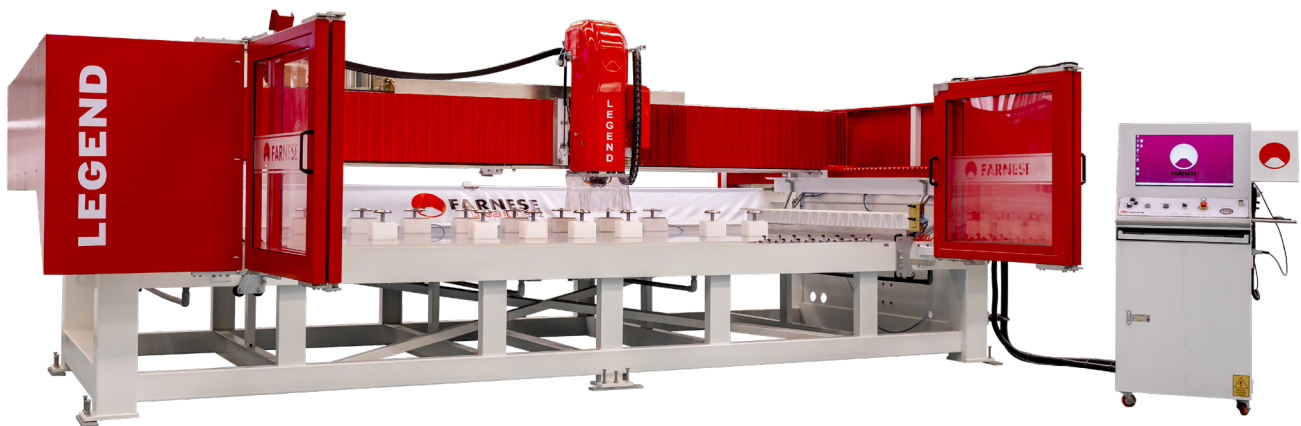

All internal and external processing is easily achievable.

- External profiling and polishing
- Undermount processing
- Tap holes
- Core drilling
- Flat drain board recesses
- Drainboard grooves

Our simple, pre-written programming is very user friendly and includes a library of all commonly used sink shapes in an easy to read menu. Additional shapes can be created easily using the parametric section, further extending the machine's capabilities.

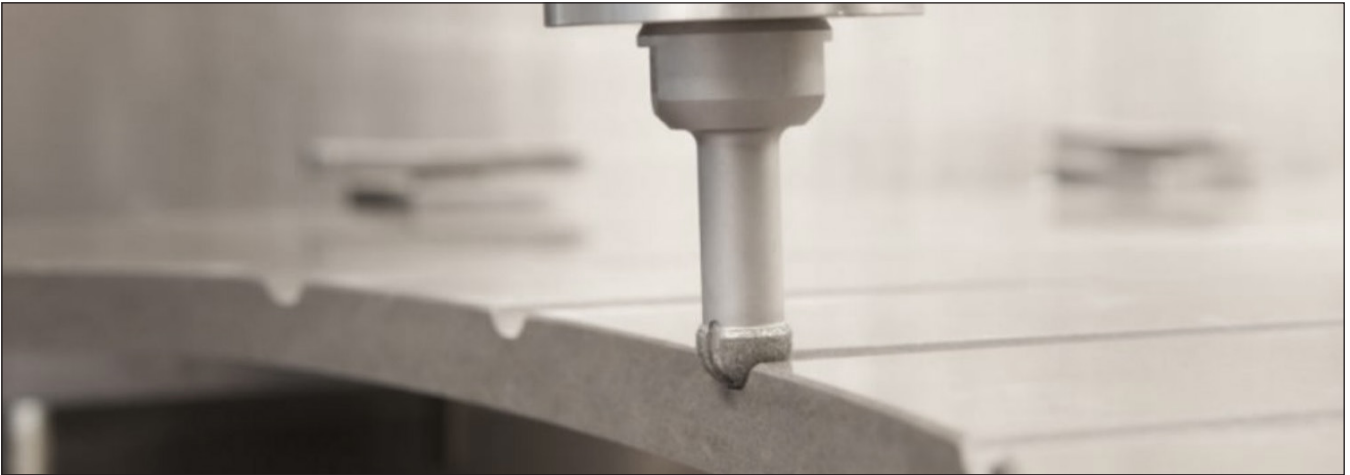

The machine also comes equipped with Tagilo CAD/CAM Software, dedicated for stone processing. For 35 years Taglio Software has been developing its own software, providing innovative technologies with very high precision, efficiency and quality. The software provides a series of CAD/CAM applications essential for design and for the processing of complex works on stone, via a DXF File.



The simplicity of the LEGEND allows even a relatively inexperienced operator to achieve great results, yet despite this simplicity, an experienced CNC operator can take full advantage of its capabilities, including CAD-CAM programming.



With the aid of Digital Measuring Devices, you will be able to measure a job directly on site, create the drawings on your preferred CAD and send them directly to the Legend for processing, saving valuable time and reducing errors.

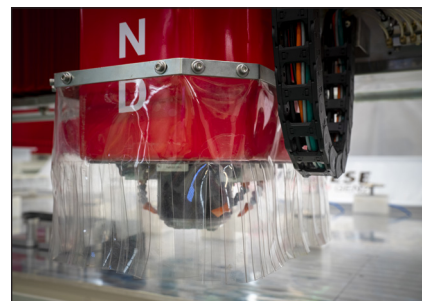

DESIGNED FOR FUNCTION, BUILT TO LAST.

LEGEND 3 AXIS CNC

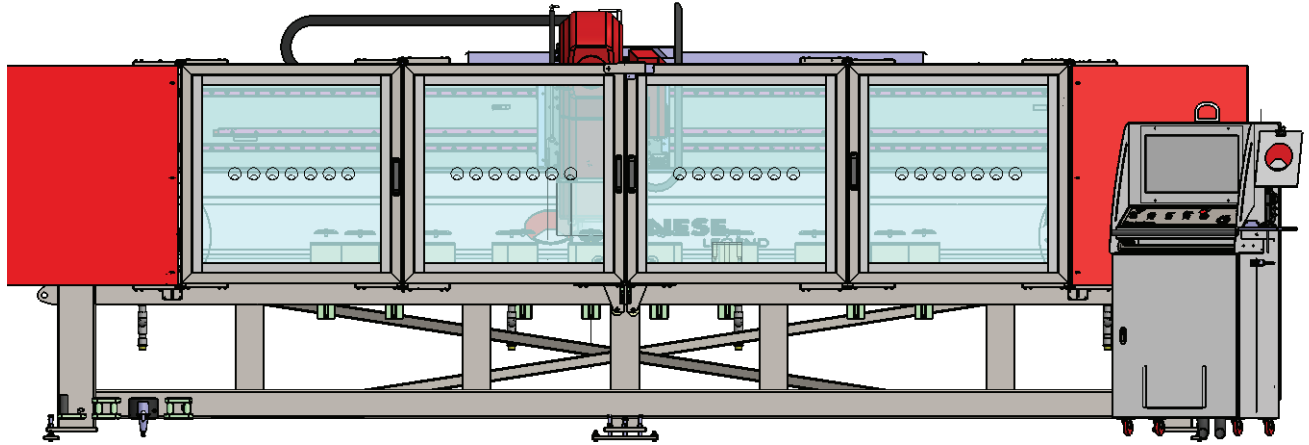

TECHNICAL SPECIFICATIONS

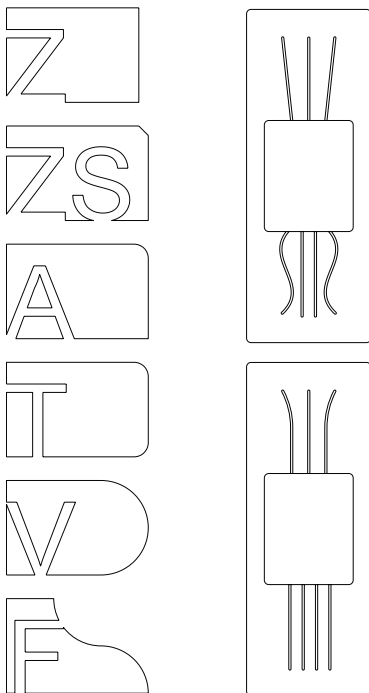

DIMENSIONS OF INSTALLED MACHINE	METRIC	IMPERIAL
LENGTH	6584 mm	259.2 in
WIDTH	3660 mm	144.1 in
HEIGHT	2500 mm	98.4 in
WEIGHT	5100 kg	11243 lb

MAX SIZE OF SLAB (Can be placed out of limit +200mm)		
LENGTH	4000 mm	157.5 in
WIDTH	2000 mm	78.7 in

FEATURES & FEEDS		
X STROKE (CROSS TRAVEL STROKE)	4600 mm	181.1 in
Y STROKE (LONG TRAVEL STROKE)	2200 mm	86.6 in
Z STROKE (HEAD UP AND DOWN)	200 mm	7.9 in
AIR PRESURE (WORKING)	7 bar	102 psi
AIR SPRESSURE (CONSUMPTION)	425 l/min	112.3 g/min
WATER (CONSUMPTION)	CLEAR	6.5 l/min 1.7 g/min
	RECYCLED	50 l/min 13.2 g/min
MAGAZINE	YES / 32 POS	YES / 32 POS
VACUUM CUPS	YES	YES
VACUUM GENERATOR	YES	YES
BACK CLAMPS	YES	YES
FRONT CLAMPS	YES	YES
AUTOMATIC GREASING	YES	YES
LASER CUTTING GUIDE	YES	YES
MICROSOFT WINDOWS COMPATIBLE	YES	YES
AUTOMATIC TOOL CHANGER	YES	YES
HANDWHEEL	YES	YES
MAIN SPINDLE POWER	15 kW	20 hp
MAIN SPINDLE SPEED (MIN & MAX)	4500 - 10000 rpm	4500 - 10000 rpm
	400v 3ph 50Hz	208v 3ph 60Hz
POWER REQUIRED	30A+ Neutral	60A

CONNECTIONS REQUIRED (SUPPLIED BY CUSTOMER)
POWER, WATER, COMPRESSED AIR

TOOLING | CONSULT YOUR LOCAL FARNESE DEALER FOR ANY TOOLING REQUIRED

Owing to the constant updating of our designs, descriptions and technical data shown in our drawings and folders are not binding. Possible alterations deemed by the makers as convenient will be effected at any time without previous notice.

5 Heald Road, Ingleburn NSW 2565 Australia
ABN: 47 057 462 629 • ACN: 057 462 629
Phone: 1300 075 678 • www.farnese.com.au

DIMENSIONS

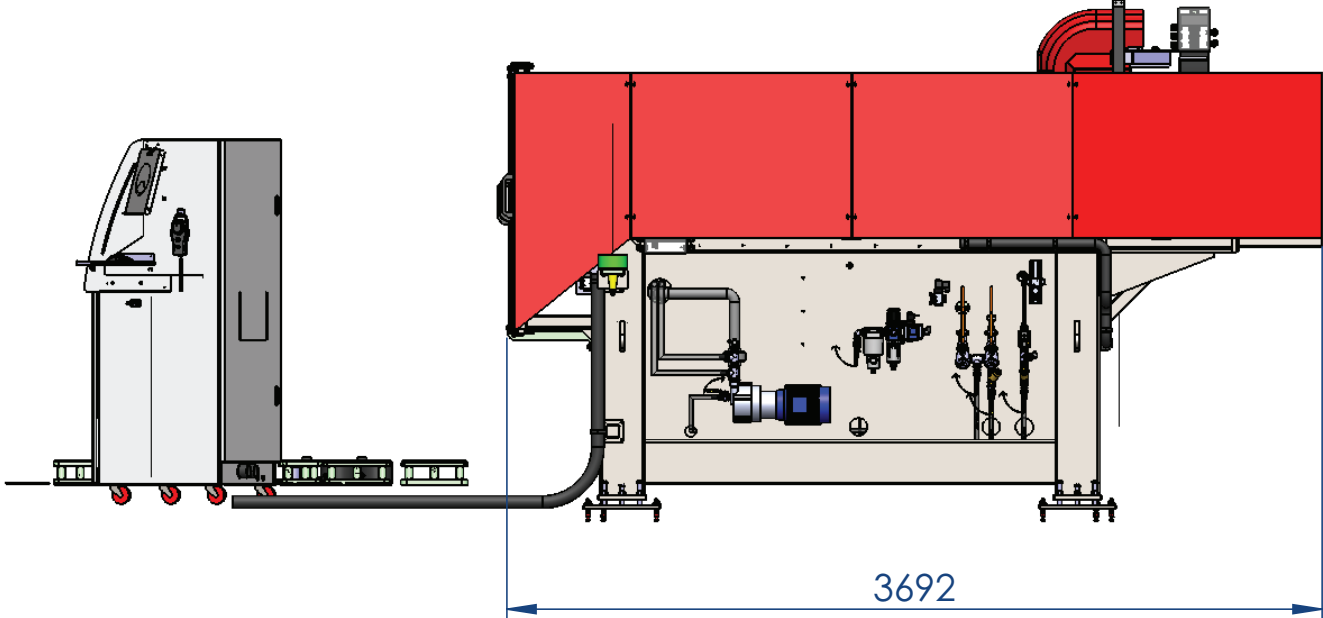
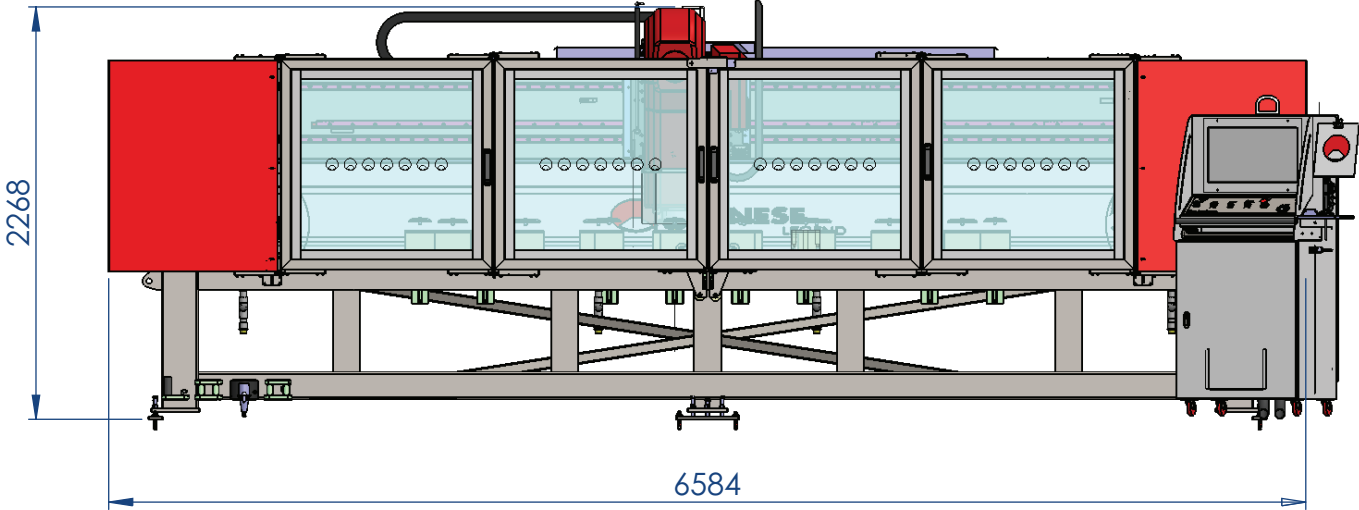



We Know That Support Is Important To You

Buying a new machine is a big commitment for anyone, and continued support throughout the life of that machine is vital.

Being an Australian company, Farnese carry a vast array of parts here in Australia to ensure that your machine always has the spares it needs. Enjoy peace of mind knowing that you'll be fully supported by Farnese and we'll always have you covered.

Farnese customers don't need to experience unnecessary machinery downtime waiting for remote assistance from other countries, as all the support and remote assistance is provided locally in Australia from our own qualified Technicians in Australian time.

With more Service Technicians in Australia than any of our competitors, our mission here at Farnese is to give you the best support in the industry. As we grow, we continue to recruit more and more qualified technicians, to further strengthen our position in the Stone Industry.

FARNESE AUSTRALIA PTY LTD 5 Heald Road, Ingleburn NSW 2565 Australia
ABN: 47 057 462 629 • ACN: 057 462 629
Phone: 1300 075 678 • www.farnese.com.au